

<b>JUNGLE<sup>4x4</sup></b>	<b>FITTING INSTRUCTIONS</b>
PRODUCT NAME:	FRONT BULLBAR
MODEL NAME:	DELUXE BAR, SPORTS BAR
CAR MODEL:	ISUZU DMAX – 2020+

## NOTE

- This product must be installed as per the instructions given below using the components supplied.
- This product must be used for specified vehicle make and model.
- All product labels should be kept untouched/not tampered with.
- This product must not be modified until otherwise mentioned/suggested.
- Professional installation of this product is recommended and requires professional tools.
- The installer should check for component clearances before finalising the installation of the product.
- Bolts/nuts fastened to specified torque unless otherwise instructed.

### Torque settings for fasteners

SIZE	TORQUE (Nm)	TORQUE (lbft)
M5	5	4
M6	9	7
M8	22	16
M10	44	32
M12	77	57

### Tools Required

Basic tool kit	Temporary marker pens
Plastic trim cutting tool/blade	Torque wrench
Tape measure	Drill with full metric drill set
Masking tape	18mm solid block



Part List		
No.	Description	Qty
1	Bull Bar D-Max 2020	1
2	Bar Mount	1
3	Recovery Point RH	1
4	Recovery Point LH	1
5	Bracket Wing Guard RH	1
6	Bracket Wing Guard LH	1
7	Tube Spacer Ø14mm x 55 mm	2
8	Under Head Light Infill RH	1
9	Under Head Light Infill LH	1
10	Sensor Plug 22 mm (Fit on Bar)	4

**Small Loop (For PJ116 only)**

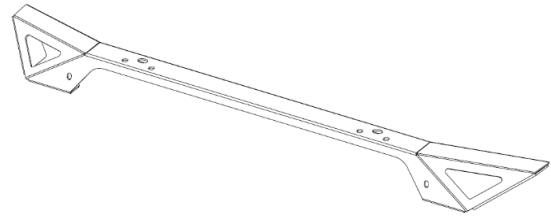

No.	Description	Qty
N/A	M6 x 1.0 x 20 Button Head Bolt	4
N/A	M6 x 1.0 Flange Nut	4
N/A	M6 x Ø19 mm Flat Washer (Black)	8

Control Winch Plate		
No.	Description	Qty
N/A	M6 x 1.0 x 25 Hex Bolt	2
N/A	M6 x 1.0 Flange Nut	4
N/A	M6 x Ø12.5 mm Flat Washer	6

Bolt Kit		
No.	Description	Qty
N/A	M6 x 1.0 x 20 Button Head Bolt	8
N/A	M6 x 1.0 Cage Nut	8
N/A	M6 x Ø18mm Flat Washer	8
N/A	M8 x 1.25 x 30 Hex Bolt	2
N/A	M8 x 1.25 Nyloc Nut	2
N/A	M8 x Ø24mm Flat Washer	4
N/A	M10 x 1.25 x 35 Hex Bolt	14
N/A	M10 x 1.25 x 90 Hex Bolt	2
N/A	M10 x 1.25 Nyloc Nut	10
N/A	M10 x Ø28mm Flat Washer	26
N/A	M12 x 1.25 x 35 Hex Bolt	8
N/A	M12 x 1.25 Nyloc Nut	8
N/A	M12 x Ø32mm Flat Washer	16

Part List for Protection Plate		
No.	Description	Qty
1	Centre Guard	1
2	Wing Guard RH	1
3	Wing Guard LH	1

Bolt Kit for Protection Plate		
No.	Description	Qty
N/A	M6 x 1.0 x 20 SS Button Head Bolt	14
N/A	M6 x Ø18 mm Flat Washer (Black)	14
N/A	M6 x 1.0 Cage Nut (for 1.5-2 mm)	10
N/A	M8 x 1.25 x 30 Hex Bolt	4
N/A	M8 x 1.25 Nyloc Nut	4
N/A	M8 x Ø22-24mm Flat Washer	8

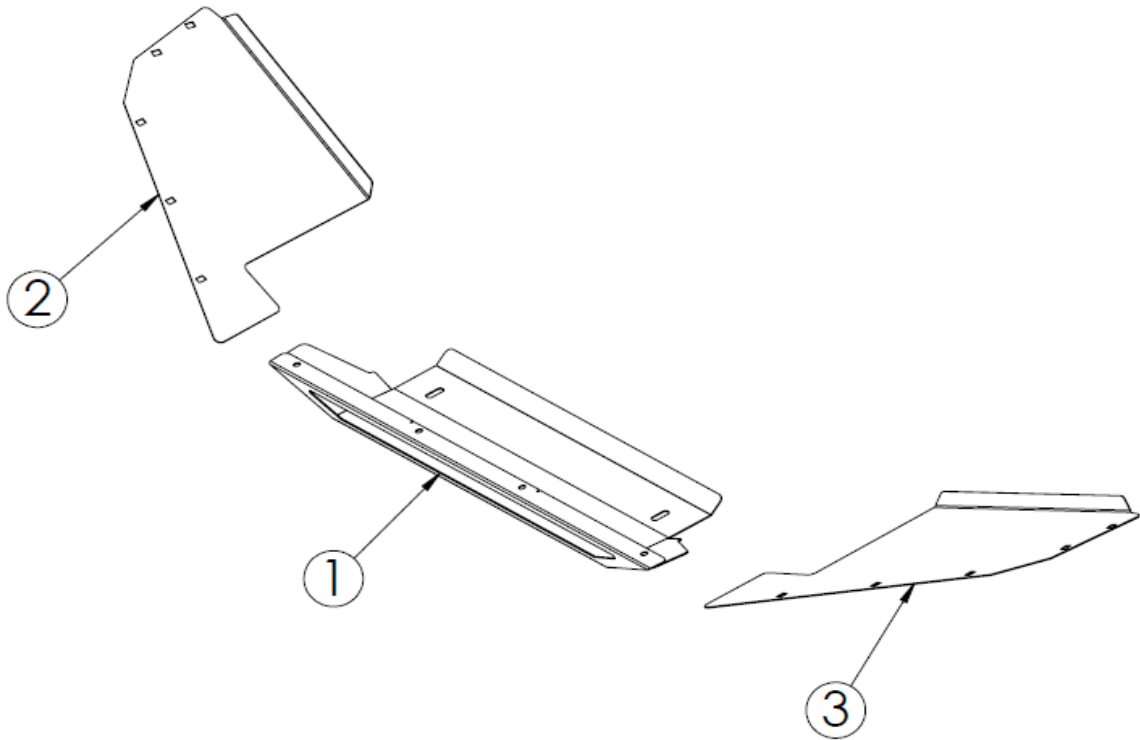
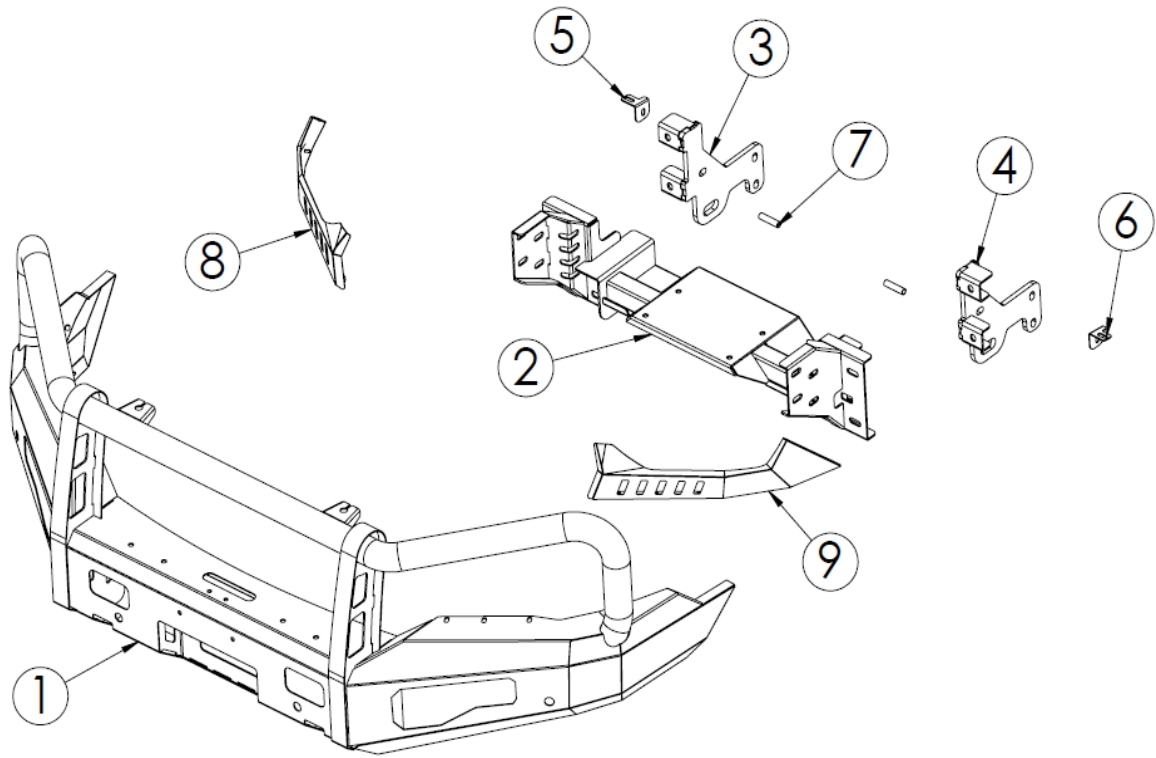



1

- Check car for damages and report if any.



2

- Undo the indicated scrivets and retain.



3

- Undo the indicated scrivets and take off the top radiator shroud and retain.



4

- Unplug all sensors and fog lights before further removal of parts.

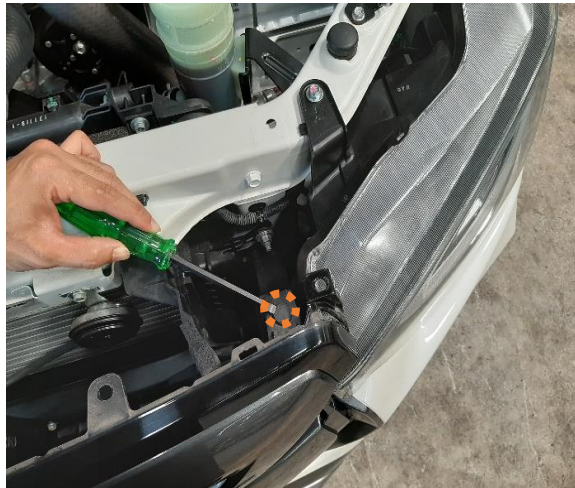

5

- Undo indicated top grill scrivet (both LHS & RHS) and retain.



6

- Undo indicated centre bolt and carefully remove the top half of the grill and retain.



7

- View of the front after top half removal.



8

- Undo indicated scrivet (both LHS & RHS) and retain.

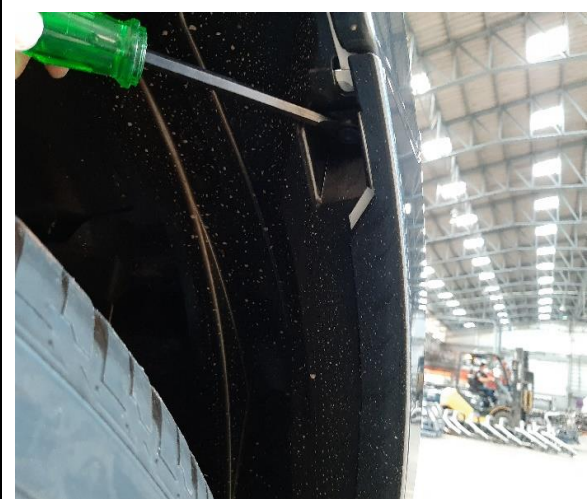

9

- Undo vertical screws in the wheel arch liner and retain.



10

- Undo indicated scrivet on the fender side.



11

- Undo indicated lower bumper scrivet and discard.

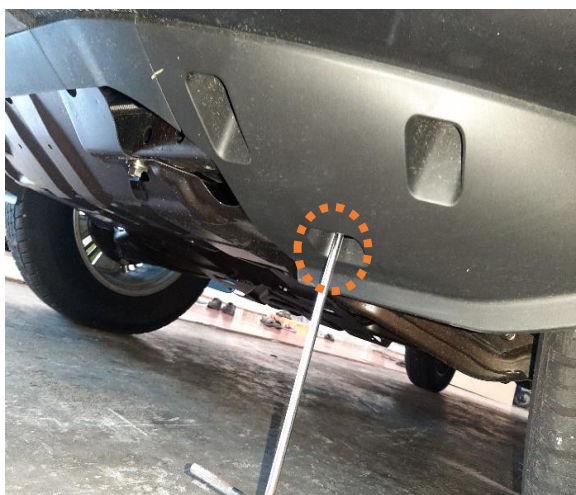

12

- Undo indicated nut in the lower half of the bumper and discard.



13

- Undo indicated screws connecting underbody protection and bumper and retain.



14

- Undo indicated internal screw on the bumper-underbody connecting bracket and discard.



15

- View of the front after bumper and grill removal.



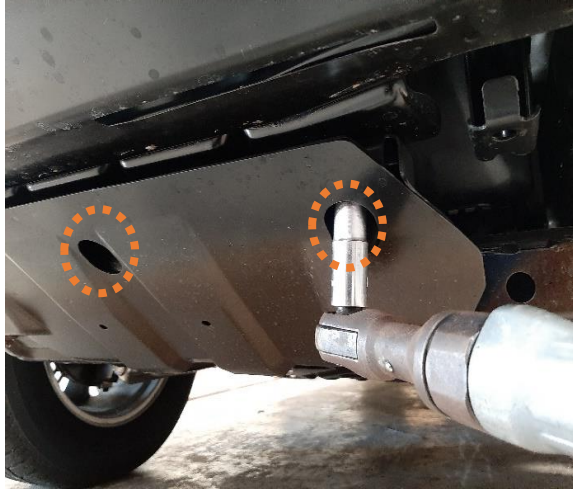

16

- ❑ Using a socket wrench, undo the indicated bolts (both left-hand side and right-hand side) and remove but retain the underbody protection plate.



17

- ❑ Using a socket wrench, undo and discard chassis cross beam.



18

- ❑ View of the front after removal of all the necessary parts.

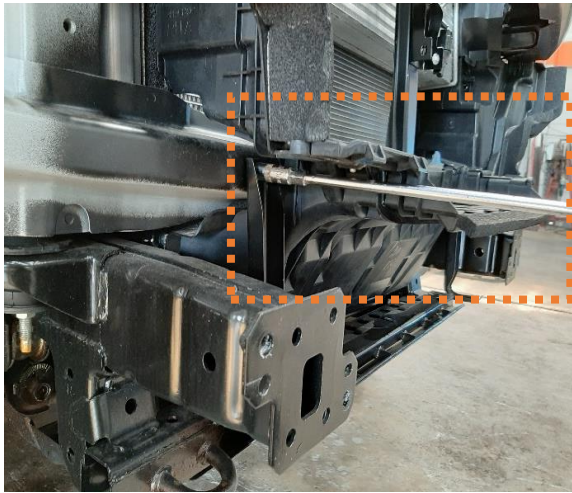

19

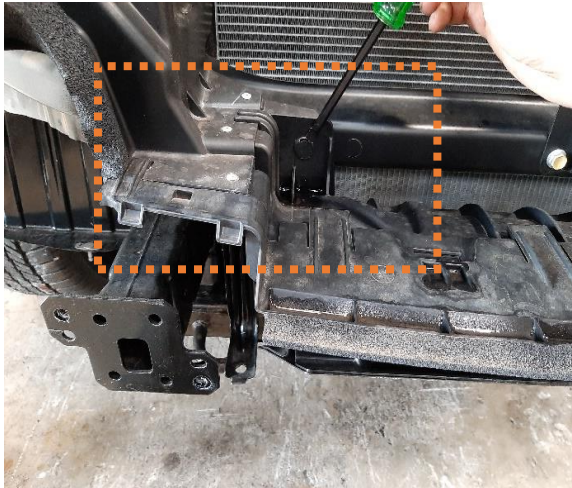

20



21

- Undo and discard all air-dam and bumper support brackets.



22

- ❑ Using a masking tape, mask along the indicated line on the lower half of the grill and make a cut.

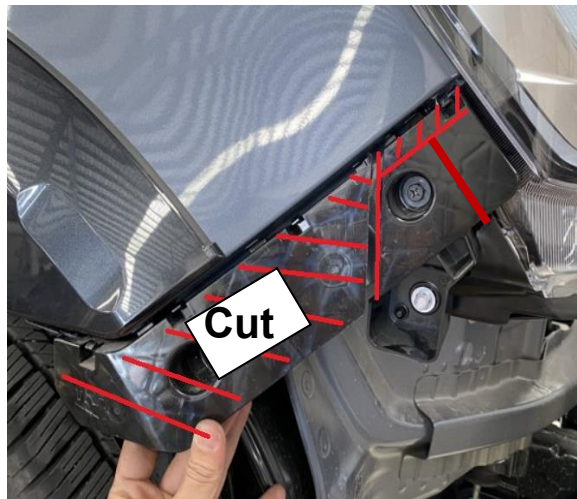

23

- ❑ Remove fender side bumper-headlight support bracket and make a cut as indicated and discard.

M10x1.25x35 Hex Bolt  
M10x28mm Flat Washer

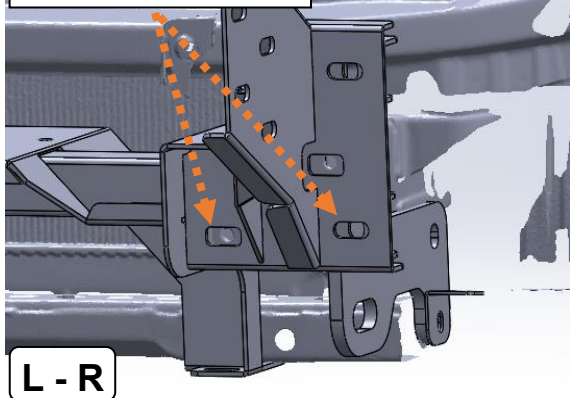

24

M10x1.25x35 Hex Bolt  
M10x28mm Flat Washer

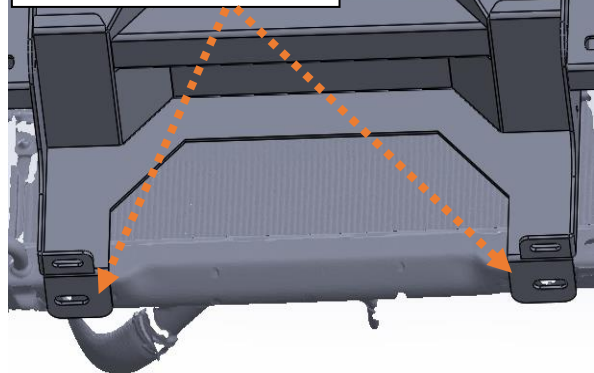

25

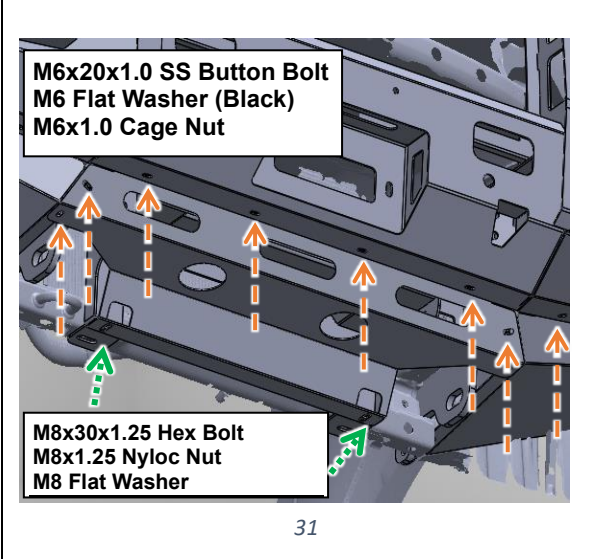
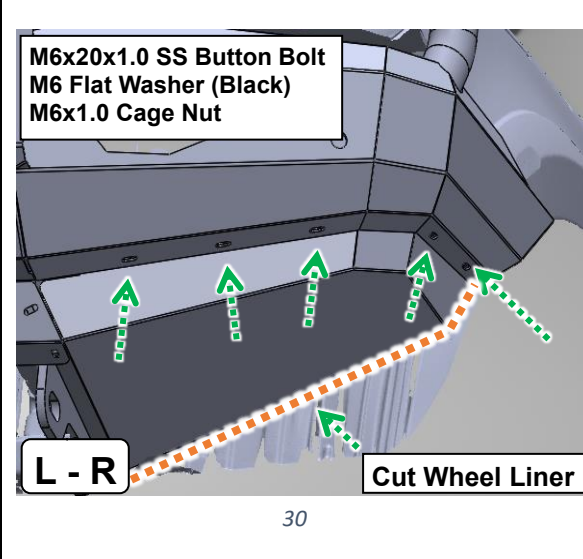
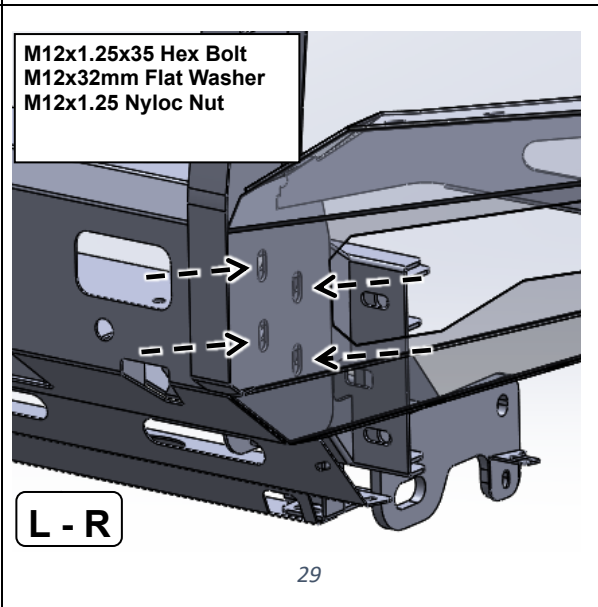
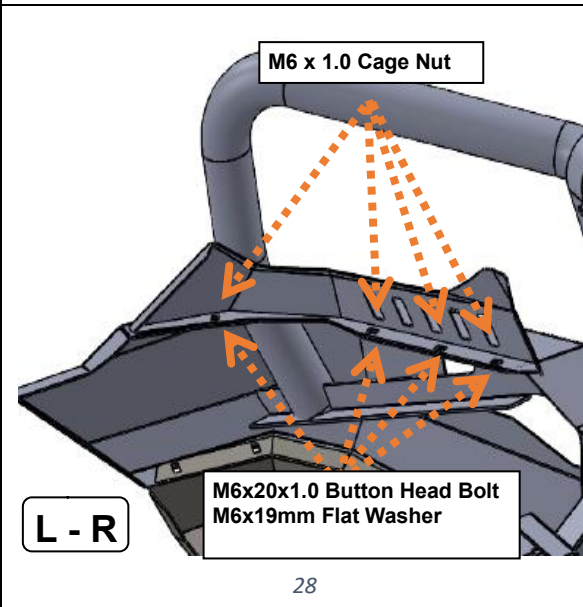
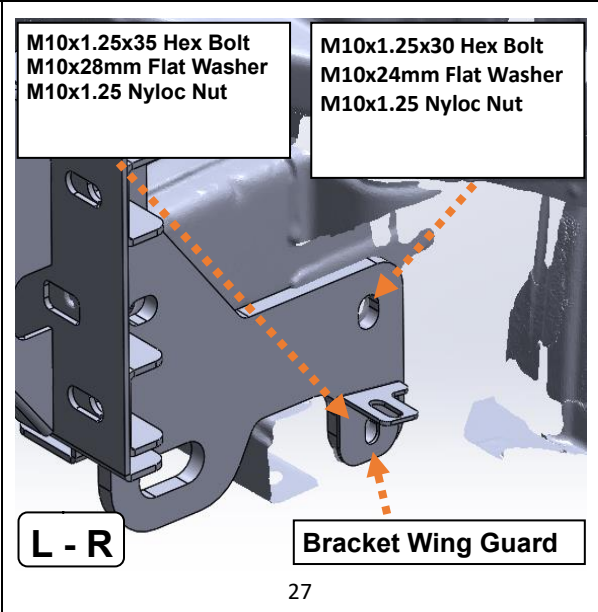
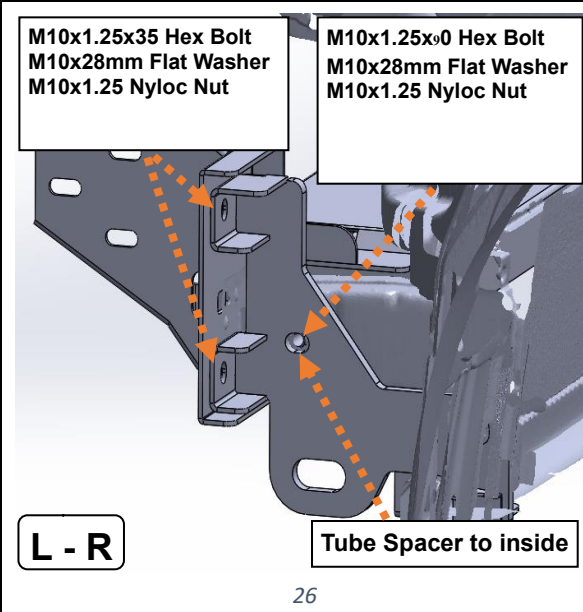

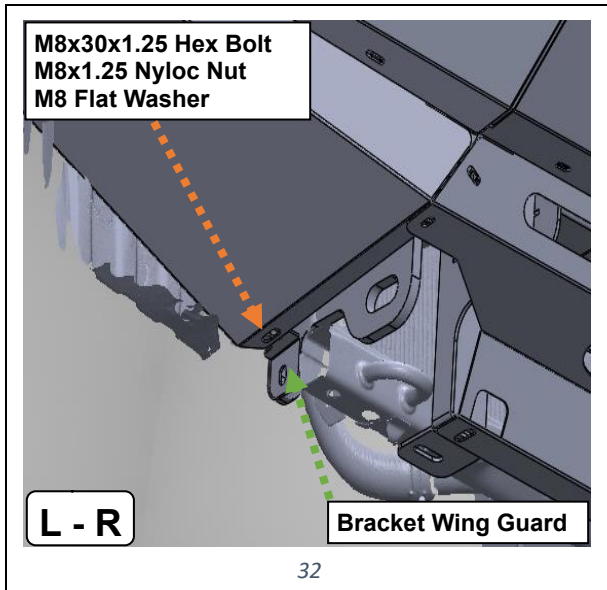

**Disclaimer:**

- For optimal fitting there should be an 18 mm gap between the bullbar and fender.
- Further fitment is at the installer's own discretion.