

<b>JUNGLE<sup>4x4</sup></b>	<b>FITTING INSTRUCTIONS</b>
PRODUCT NAME:	FRONT BULLBAR
MODEL NAME:	DELUXE BAR, SPORTS BAR
CAR MODEL:	MITSUBISHI TRITON 2019-2023

## NOTE

- This product must be installed as per the instructions given below using the components supplied.
- This product must be used for specified vehicle make and model.
- All product labels should be kept untouched/not tampered with.
- This product must not be modified until otherwise mentioned/suggested.
- Professional installation of this product is recommended and requires professional tools.
- The installer should check for component clearances before finalising the installation of the product.
- Bolts/nuts fastened to specified torque unless otherwise instructed.

### Torque settings for fasteners

SIZE	TORQUE (Nm)	TORQUE (lb ft)
M5	5	4
M6	9	7
M8	22	16
M10	44	32
M12	77	57

### Tools Required

Basic tool kit	Temporary marker pens
Plastic trim cutting tool/blade	Torque wrench
Tape measure	Drill with full metric drill set
Masking tape	18mm solid block



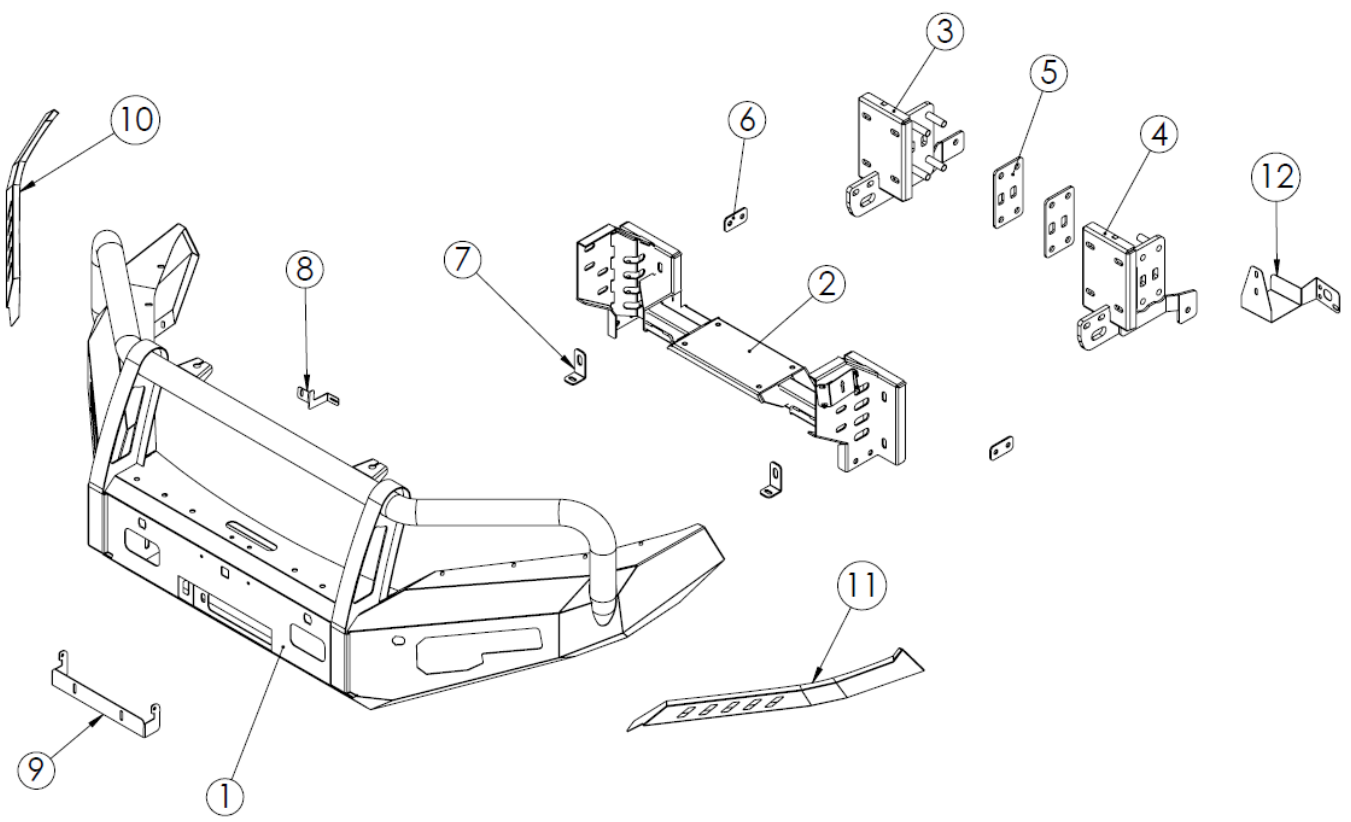

Part List		
No.	Description	Qty
1	Bull Bar Mitsubishi Triton 2019	1
2	Bar Mount	1
3	Recovery Point RH	1
4	Recovery Point LH	1
5	Plate (170x95x6mm)	2
6	Washer Plate (75x40x4mm)	2
7	Bracket Centre Guard	2
8	Bracket Centre Grill	1
9	License Plate Bracket	1
10	Under Head Light Infill RH	1
11	Under Head Light Infill LH	1
12	Water Tank Bracket	1
N/A	Water Tank	1
N/A	Plastic Hose for Water Tank	1

Bolt Kit		
No.	Description	Qty
N/A	M5 x 0.8 Flange Nut	2
N/A	M5 x 0.8 x 20 Pan Head Screw	2
N/A	M6 x 1.0 x 20 Button Head Bolt	15
N/A	M6 x 1.0 Flang Nut	9
N/A	M6 x 1.0 Nyloc Nut	2
N/A	M6 x Ø12.5mm Flat Washer	24
N/A	M6 x 1.0 Cage Nut (For 1.5-2 mm)	8
N/A	M8 x 1.25 Nyloc Nut	3
N/A	M8 x Ø24mm Flat Washer	5
N/A	M10 x 1.25 x 35 Hex Bolt	1
N/A	M10 x 1.25 x 40 Hex Bolt	3
N/A	M10 x 1.25 x 35 Plate Bolt	4
N/A	M10 x 1.25 Nyloc Nut	6
N/A	M10 x Ø28mm Flat Washer	10
N/A	M10 Spring Washer	6
N/A	M12 x 1.25 x 35 Hex Bolt	12
N/A	M12 x 1.25 x 100 Hex Bolt	10
N/A	M12 x 1.25 x 50 Plate Bolt	2
N/A	M12 x 1.25 x 35 Plate Bolt	8
N/A	M12 x 1.25 Nyloc Nut	32
N/A	M12 x Ø32mm Flat Washer	60
Factory Fitted		
N/A	M6 x 1.0 x 20 Plate Bolt (24x70 mm) (Fit on Water Tank)	1



- Check car for damages and report if any.



- Undo indicated top radiator shroud screws (LHS & RHS) and retain.



- Undo indicated screw and retain.

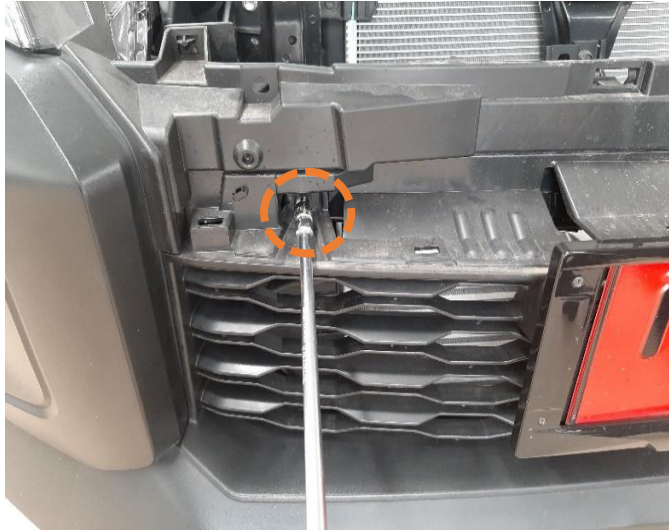

- ❑ Undo indicated bumper bolts (LHS & RHS) and discard.



- ❑ Undo indicated centre bumper bolt and discard.

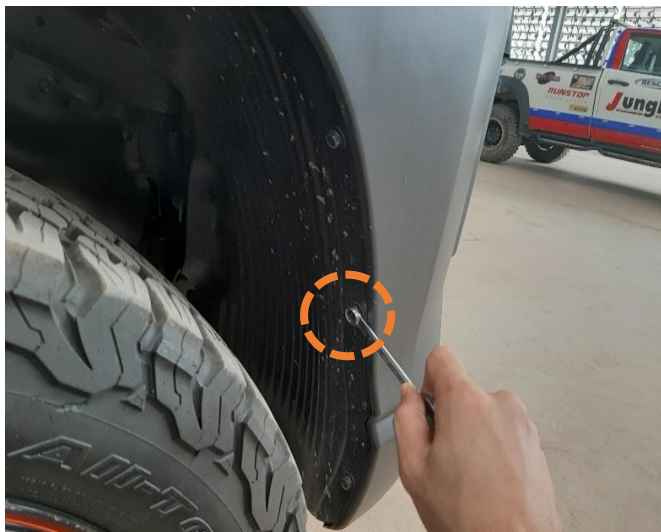

- ❑ Undo indicated wheel arch scrivet (LHS & RHS) and retain.



- ❑ Undo indicated wheel arch scrivet (LHS & RHS) and retain.

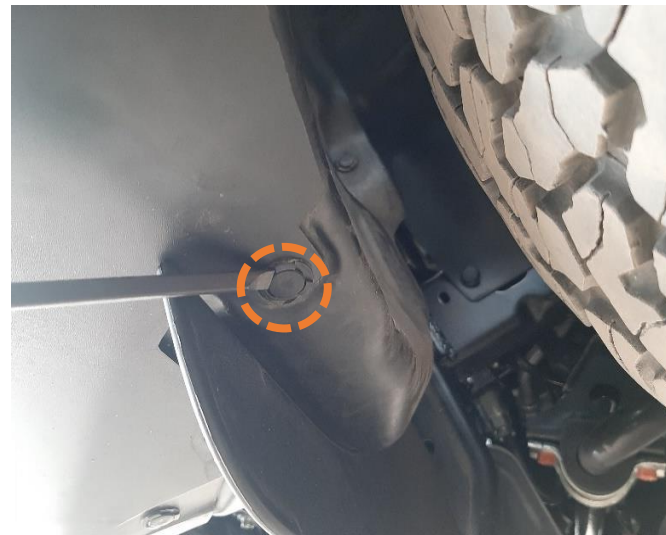

- ❑ Undo indicated mudflap scrivets and discard.





- ❑ Undo indicated air dam scrivets and discard.

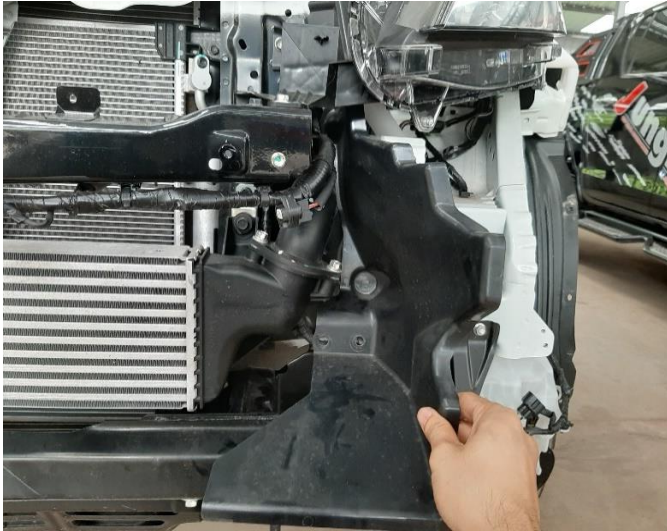

- Remove air dam components and discard



- Undo indicated bolts and discard.



- Frontal view after components removal.





- Undo indicated washer bottle hose support scrivet.



- Undo and retain the hose.

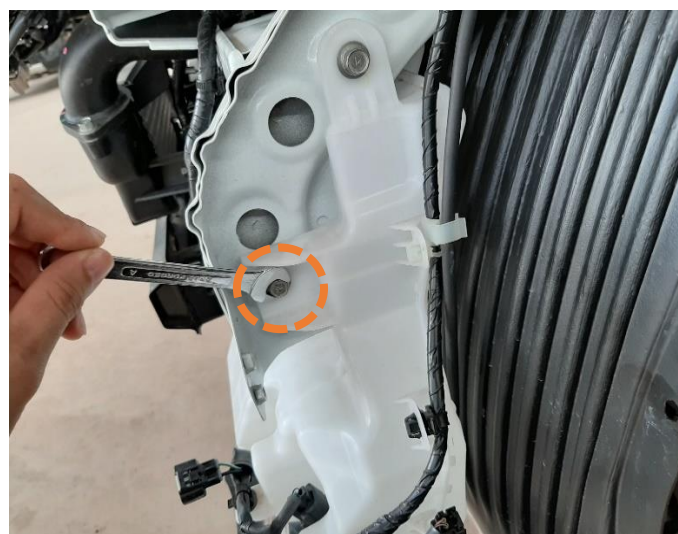

- Undo indicated bolt and discard.



- Undo indicated bolt and discard.

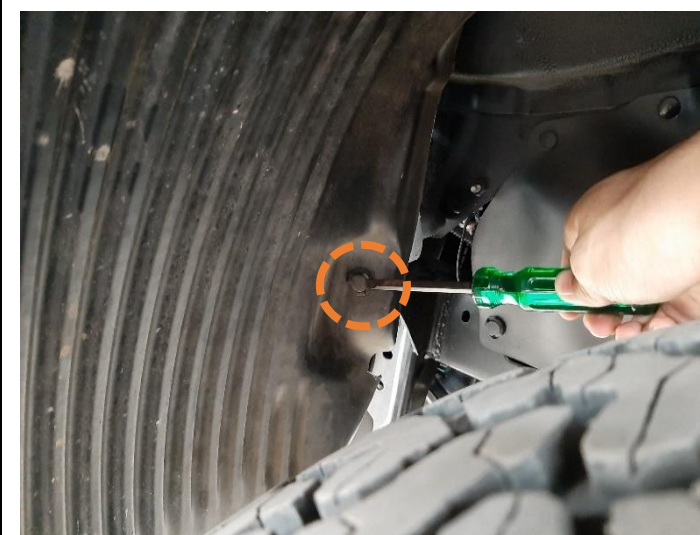

- Undo indicated scrivet and bolt to loosen up the washer bottle.

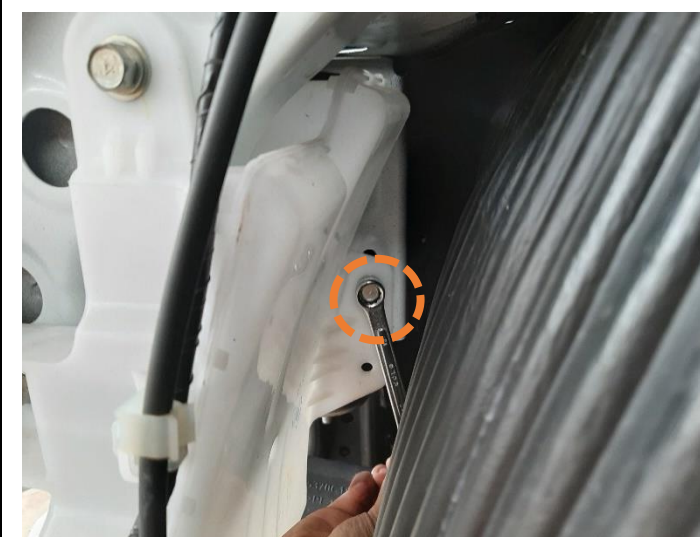



- Remove and retain washer bottle.



- Side view of the car after component removal.



- Align grill support bracket provided in the fitting kit as indicated.

M6x1.0x20 Button Head Bolt  
M6x12.5mm Flat Washer  
M6x1.0 Flange Nut



- ❑ Install the grill back using the grill support bracket using the bolt kit provided.

M12 x 1.25 x 50 Plate Bolt

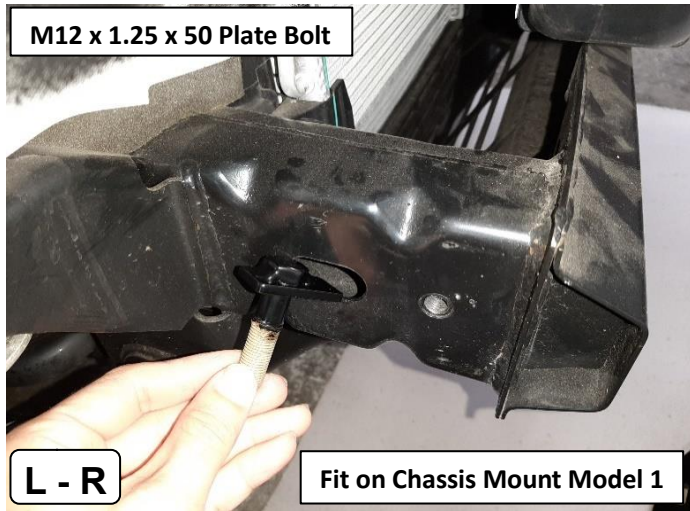

L - R

Fit on Chassis Mount Model 1

- ❑ Place the M12 bolt on plates as indicated.

M12 x 1.25 x 100 Hex Bolt

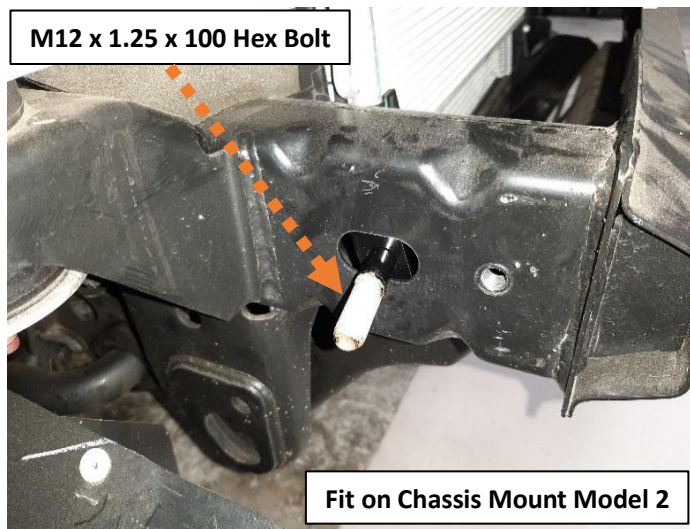

Fit on Chassis Mount Model 2

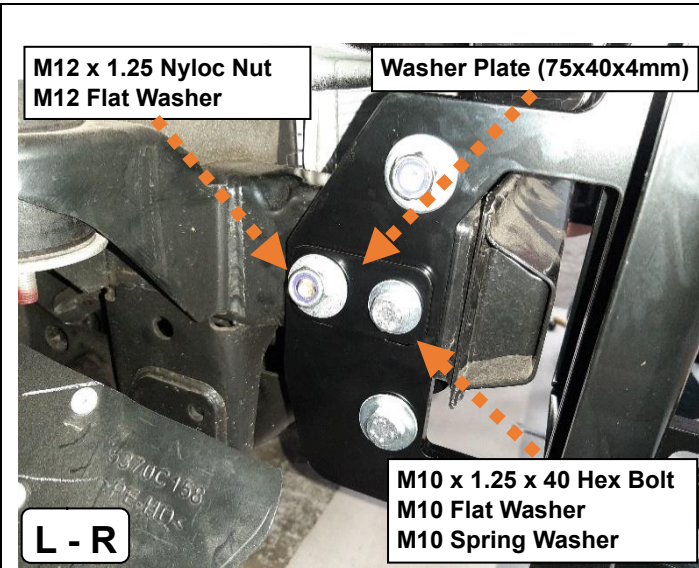

- ☐ Mount recovery point assembly as indicated.

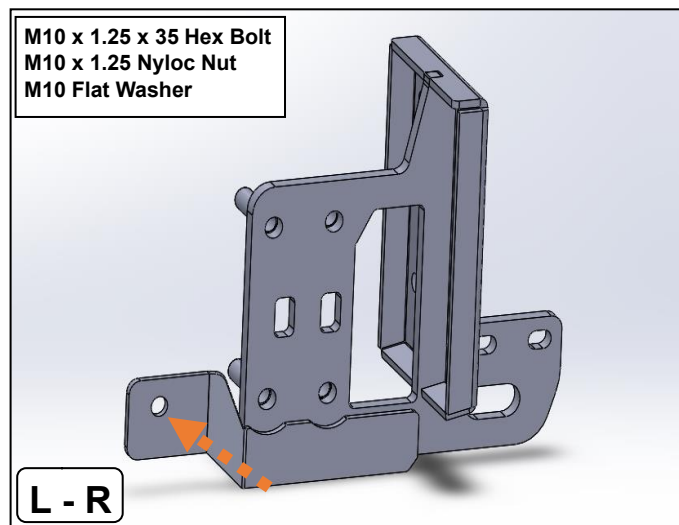
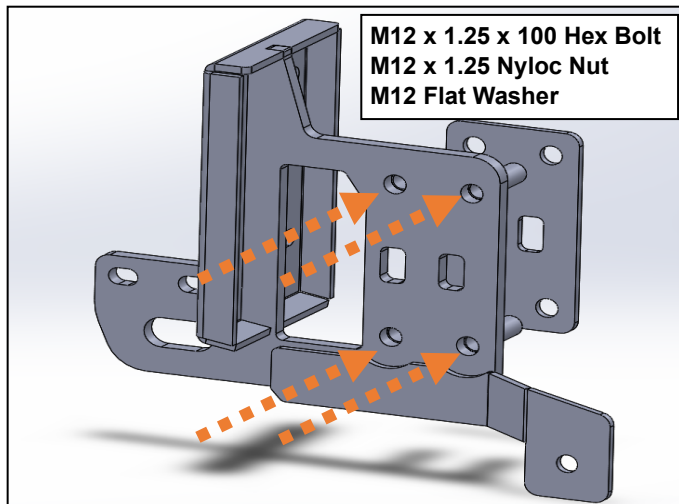

- ☐ Mount support bracket using the bolts provided in the bolt kit.

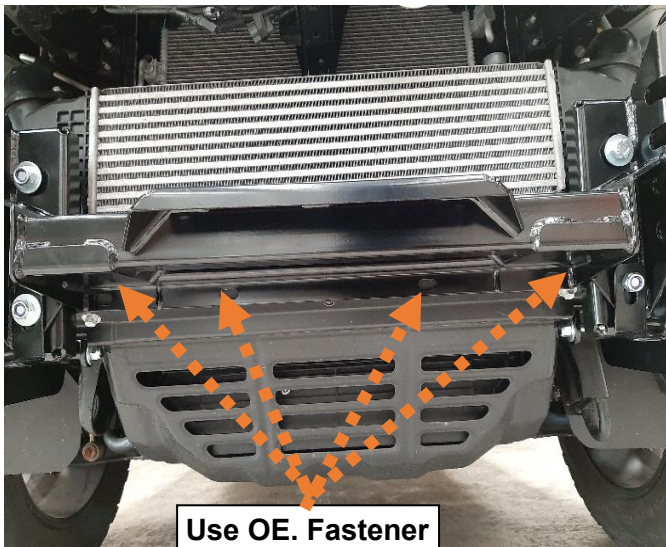

**Use OE. Fastener**

- ❑ If the cross beam is of this kind and shape, please use OE fasteners to mount underbody.

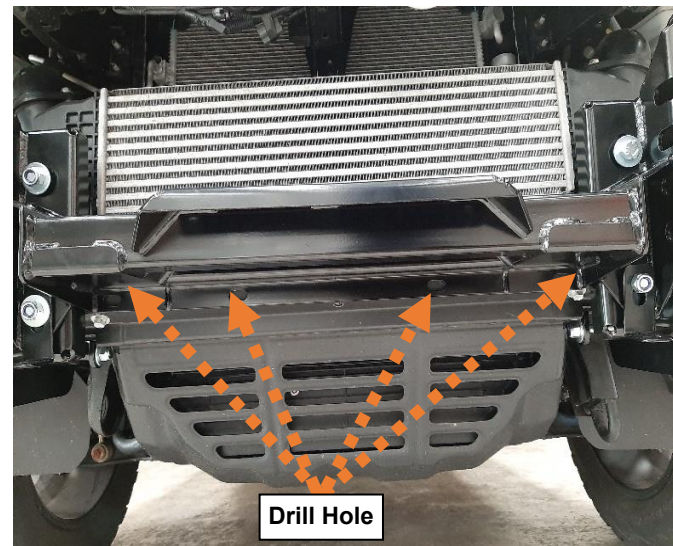
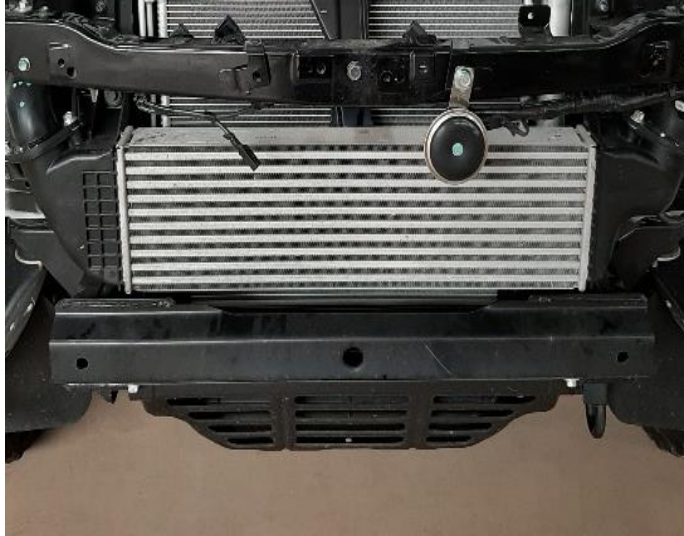

- ❑ If the cross beam is of this kind and shape, please drill M10 holes and use M10 x 1.25 x 35 bolts on plate with a M10 x 1.25 Nyloc nut and a M10 flat washer.

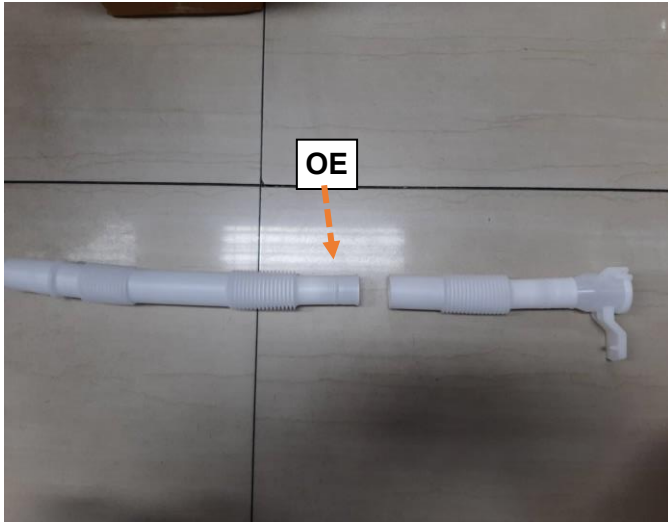

M6x1.0 Flange Nut  
M6 Flat Washer

M8 x 1.25 Nyloc Nut  
M8 Flat Washer

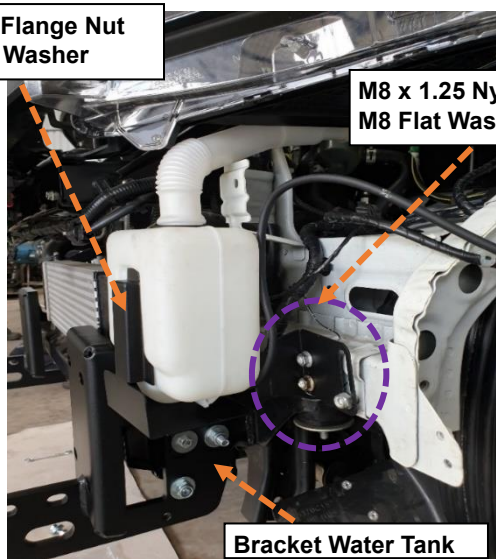

Bracket Water Tank

- ❑ Assemble OE tubes and use OE O-ring to ensure good seal.
- ❑ Instal washer bottle using the bracket and bolt kit provided with the fitting kit.
- ❑ Check for any loose connections before finalising.





- ❑ Use the OE scrivet to support the tube as indicated.

M6 x 1.0 Cage Nut

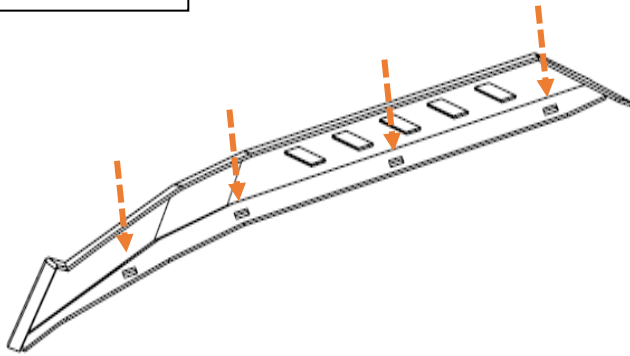

L - R

M6 x 1.0 x 20 Button Head Bolt  
M6 x  $\phi$ 12.5 Flat Washer

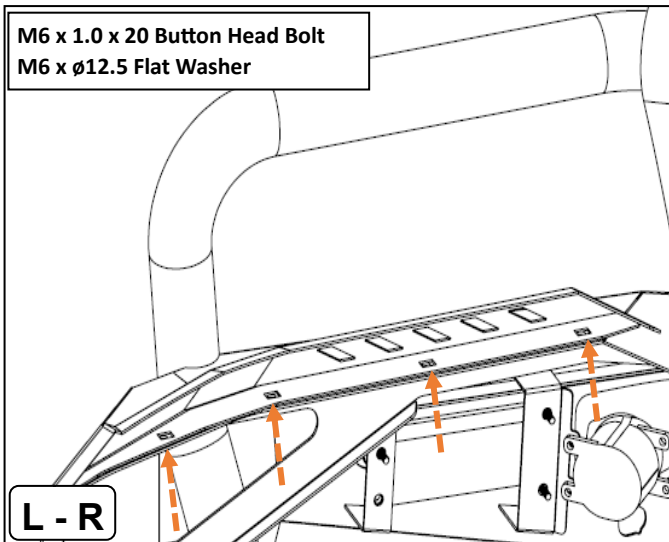

L - R

- ❑ Install wing infill on the bullbar using the bolt provided with the fitting kit.

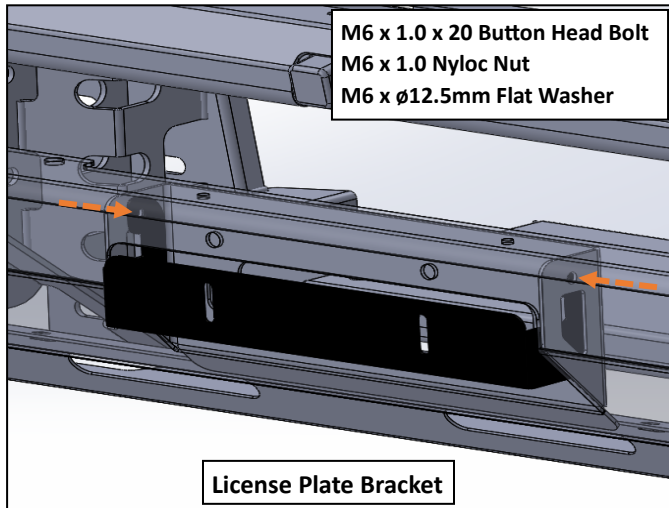
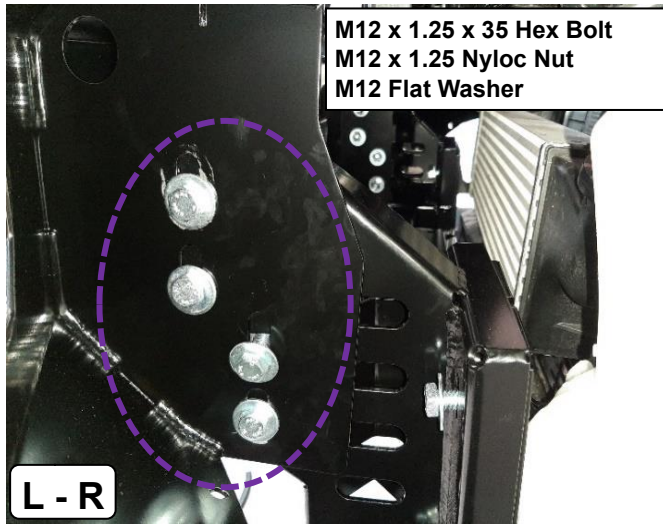

- Install bullbar to the cradle using the bolt kit provided.
- Mount the license plate bracket at the end.

**Disclaimer:**

- For optimal fitting there should be an 18 mm gap between the bullbar and fender and parallel to the fender line.
- Further fitment is at the installer's own discretion.